



az

pneumatica

agility in automation

Cilindri pressori

Clamping cylinders



Cilindri pressori

Clamping cylinders



- Cilindri semplice effetto antirotazione, molla anteriore
Single acting front spring cylinders, anti-rotation
- Non magnetici
Non-magnetic
- Ottimi per il serraggio dei pezzi da tagliare su macchine troncatrici per alluminio, plastica o legno
Very good cylinders to clamp the pieces in sawing machines for aluminium, plastic or wood



modello <i>model</i>	alesaggio interno <i>internal bore</i>	corsa <i>stroke</i>	esecuzione <i>execution</i>
17.066.0	25 mm	8 mm	con tampone di spinta [with pushing pad]
17.062.0	25 mm	75 mm	con tampone di spinta [with pushing pad]
17.067.0	25 mm	110 mm	con tampone di spinta [with pushing pad]
17.068.0	35 mm	8 mm	con tampone di spinta [with pushing pad]
17.060.0	35 mm	75 mm	con tampone di spinta [with pushing pad]
17.061.0	35 mm	110 mm	con tampone di spinta [with pushing pad]
17.069.0	35 mm	75 mm	con tampone di spinta e testata anteriore filettata [with pushing pad and threaded front end cap]
17.129.0	40 mm	8 mm	con tampone di spinta [with pushing pad]
17.130.0	40 mm	20 mm	con tampone di spinta [with pushing pad]
17.131.0	40 mm	60 mm	con tampone di spinta [with pushing pad]
17.113.0	40 mm	75 mm	con tampone di spinta [with pushing pad]
17.128.0	40 mm	110 mm	con tampone di spinta [with pushing pad]
17.132.0	50 mm	8 mm	con tampone di spinta [with pushing pad] lunghezza cilindro 130 mm [cylinder length 130 mm]
17.133.0	50 mm	8 mm	con tampone di spinta [with pushing pad] lunghezza cilindro 200 mm [cylinder length 200 mm]
17.134.0	50 mm	55 mm	con tampone di spinta [with pushing pad]
17.135.0	50 mm	75 mm	con tampone di spinta [with pushing pad]
17.136.0	50 mm	120 mm	con tampone di spinta [with pushing pad]

Materiali

Corpo: alluminio anodizzato
Stelo: AVP zincato
Guarnizioni: NBR e poliuretano
Distanziale: tecnopolimero
Molla: acciaio al carbonio grado SH

Materials

Body: aluminium (anodize treatment)
Piston-rod: zinc plated AVP steel
Sealings: NBR and polyurethane
Spacer: technopolymer
Spring: SH grade carbon steel

Pressione di esercizio <i>Working pressure</i>	2 ... 10 bar
Temperatura di esercizio <i>Temperature range</i>	-10°C ... +60°C
Fluido <i>Fluid</i>	Aria filtrata 50µ con o senza lubrificazione <i>50µ filtered, lubricated or non lubricated air</i>

Cilindri pressori

Clamping cylinders



alesaggio interno 25 mm; corsa 8 mm e 75 mm

internal bore 25 mm; stroke 8 mm and 75 mm

17.066.0
17.062.0

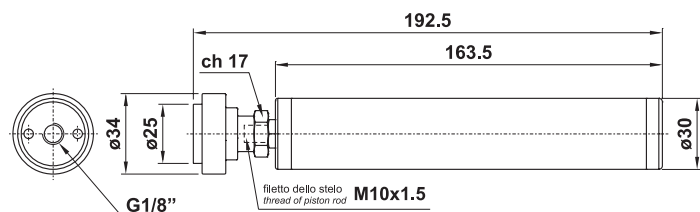

alesaggio interno 25 mm; corsa 110 mm

internal bore 25 mm; stroke 110 mm

17.067.0

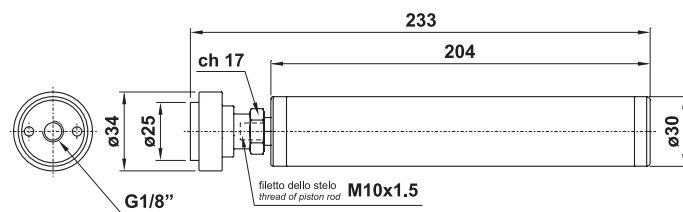

alesaggio interno 35 mm; corsa 8 mm e 75 mm

internal bore 35 mm; stroke 8 mm and 75 mm

17.068.0
17.060.0

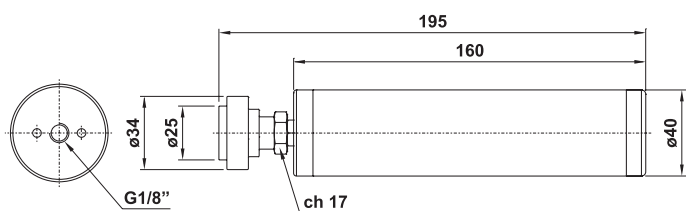

alesaggio interno 35 mm; corsa 110 mm

internal bore 35 mm; stroke 110 mm

17.061.0

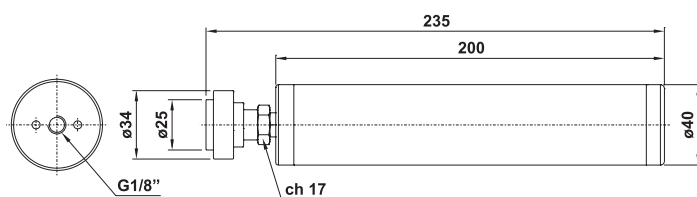

alesaggio interno 35 mm; corsa 75 mm; testata filettata

internal bore 35 mm; stroke 75 mm; threaded front end cup

17.069.0

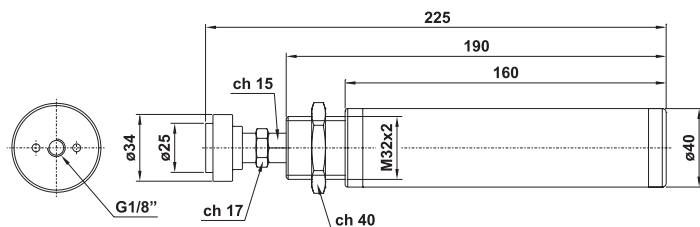

RICAMBI - spare parts

tampone per cilindro pressore
pad for clamping cylinder

17.074.0



Cilindri pressori

Clamping cylinders



alesaggio interno 40 mm; corsa 8 mm e 20 mm
internal bore 40 mm; stroke 8 mm and 20 mm

17.129.0
17.130.0

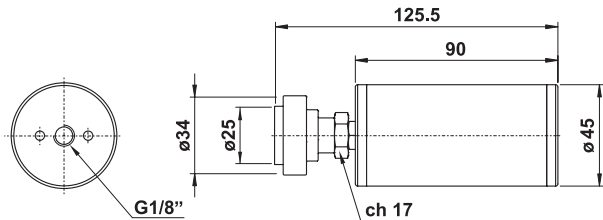

alesaggio interno 40 mm; corsa 60 mm
internal bore 40 mm; stroke 60 mm

17.131.0

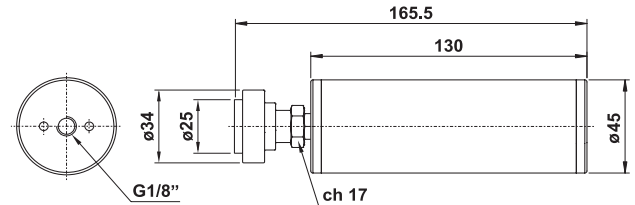

alesaggio interno 40 mm; corsa 75 mm
internal bore 40 mm; stroke 75 mm

17.113.0

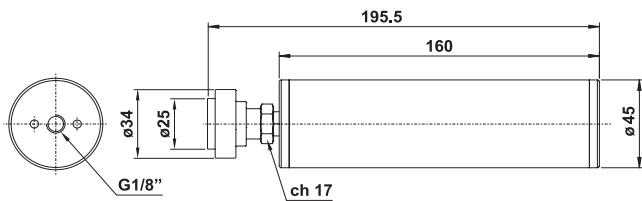

alesaggio interno 40 mm; corsa 110 mm
internal bore 40 mm; stroke 110 mm

17.128.0

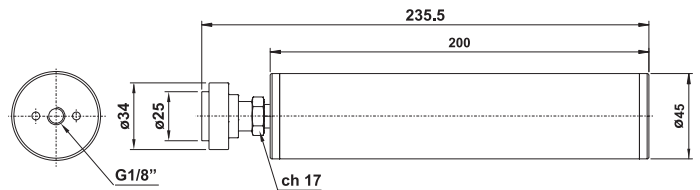

alesaggio interno 50 mm; corsa 8 mm e 55 mm
internal bore 50 mm; stroke 8 mm and 55 mm

17.132.0
17.134.0

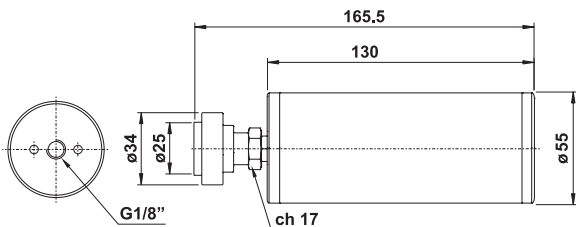

alesaggio interno 50 mm; corsa 8 mm, 75 mm e 120 mm
internal bore 50 mm; stroke 8 mm, 75 mm and 120 mm

17.133.0
17.135.0
17.136.0

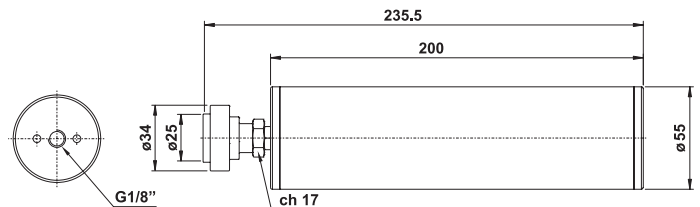

RICAMBI - spare parts

tampone per cilindro pressore
pad for clamping cylinder

17.074.0



Cilindri pressori con valvola di blocco integrata



Clamping cylinders with integrated pneumatically piloted stop valve

- Cilindri semplice effetto antirotazione, molla anteriore
Single acting front spring cylinders, anti-rotation
- Non magnetici
Non-magnetic
- Ottimi per il serraggio dei pezzi da tagliare su macchine troncatrici per alluminio, plastica o legno
Very good cylinders to clamp the pieces in sawing machines for aluminium, plastic or wood
- Valvola di blocco a comando pneumatico G1/8" integrata
Integrated pneumatically piloted G1/8" stop valve

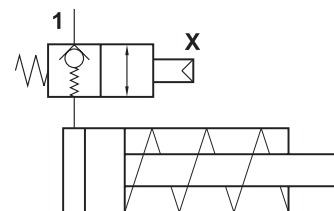

Materiali

Corpo: alluminio anodizzato
Stelo: AVP zincato
Guarnizioni: NBR e poliuretano
Distanziale: tecnopolimero
Molla: acciaio al carbonio grado SH

Materials

*Body: aluminium (anodize treatment)
Piston-rod: zinc plated AVP steel
Sealings: NBR and polyurethane
Spacer: technopolymer
Spring: SH grade carbon steel*

modello model	alesaggio interno internal bore	corsa stroke	esecuzione execution
17.005.4	35 mm	8 mm	con tampone di spinta [with pushing pad]
17.006.4	35 mm	75 mm	con tampone di spinta [with pushing pad]
17.007.4	35 mm	110 mm	con tampone di spinta [with pushing pad]
17.008.4	35 mm	75 mm	con tampone di spinta e testata anteriore filettata [with pushing pad and threaded front end cap]

Pressione di esercizio <i>Working pressure</i>	2 ... 10 bar
Temperatura di esercizio <i>Temperature range</i>	max +60°C
Fluido <i>Fluid</i>	Aria filtrata 50µ con o senza lubrificazione 50µ filtered, lubricated or non lubricated air

Cilindri pressori con valvola di blocco integrata



Clamping cylinders with integrated pneumatically piloted stop valve

alesaggio interno 35 mm; corsa 8 mm e 75 mm

internal bore 35 mm; stroke 8 mm and 75 mm

17.005.4

17.006.4

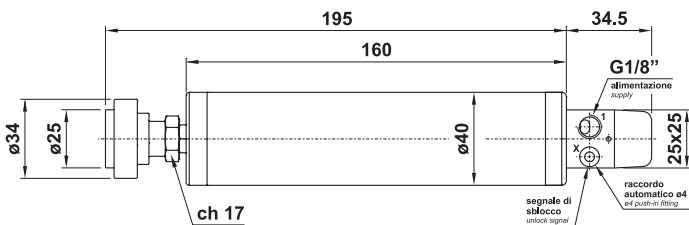

alesaggio interno 35 mm; corsa 110 mm

internal bore 35 mm; stroke 110 mm

17.007.4

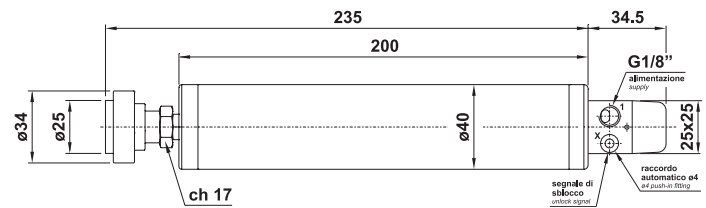

alesaggio interno 35 mm; corsa 75 mm; testata filettata

internal bore 35 mm; stroke 75 mm; threaded front end cup

17.008.4

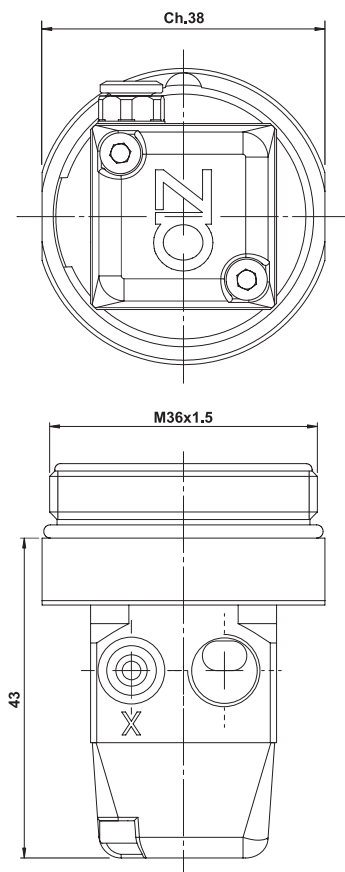
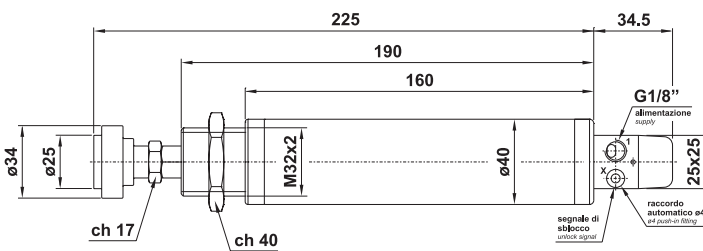

RICAMBI - spare parts

valvola di blocco

pneumatically piloted stop valve

11.094.4



agility in automation

AZ Pneumatica srl
Via Marco Biagi, 6
20826 Misinto (MB) - Italia
☎ +39 0296691100
✉ info@azpneumatica.it



azpneumatica.com

